

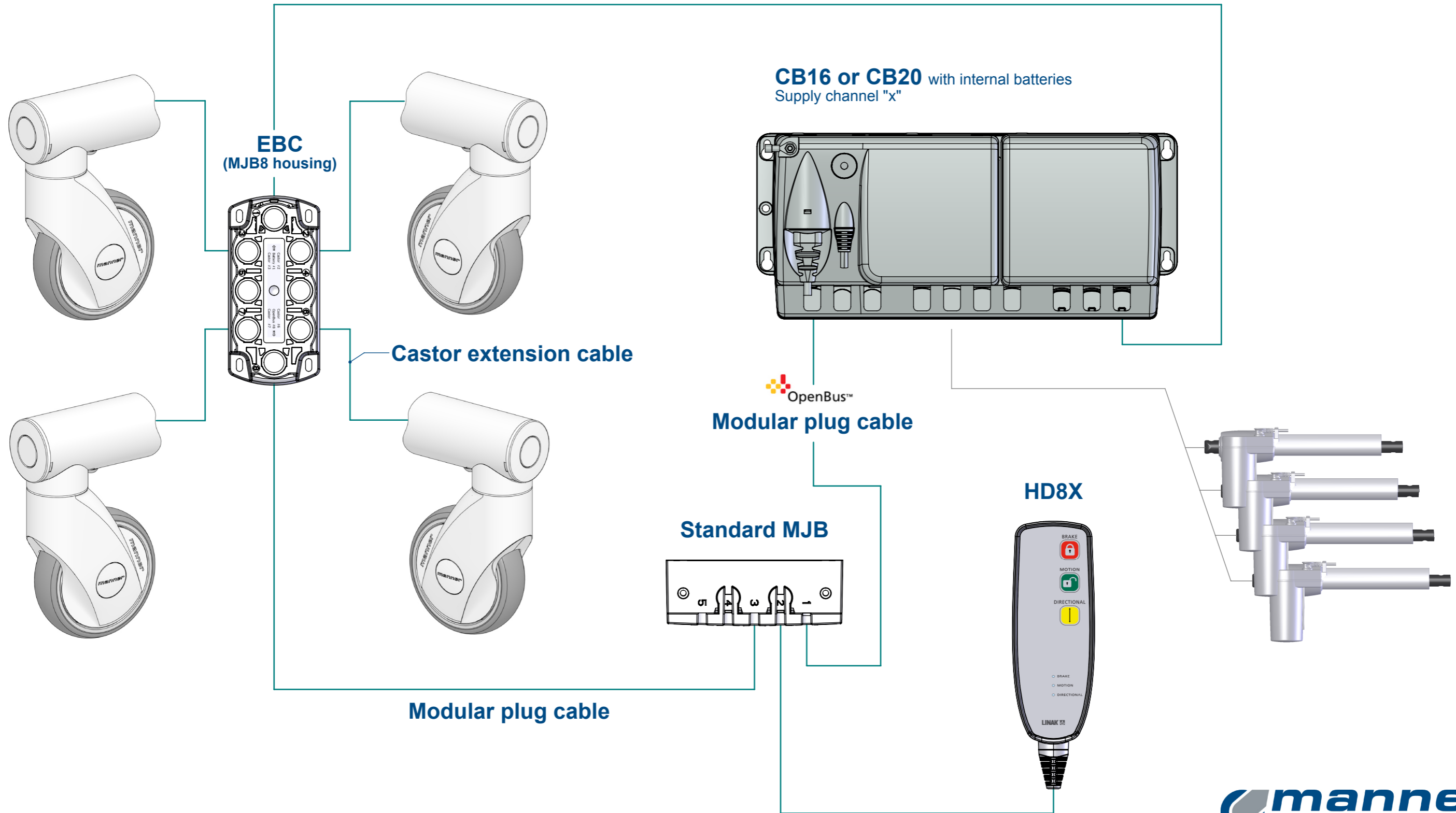

# Electrical Brake Control

## CB16/20 System Overview

Cable between CB16/CB20 & EBC



## CONTROL SYSTEM COMPONENTS

### Handset HD8X

Model: *HD8X081-00*

Weight: 295g

Cable length: 600mm (spiral)

Protection class: IPX4

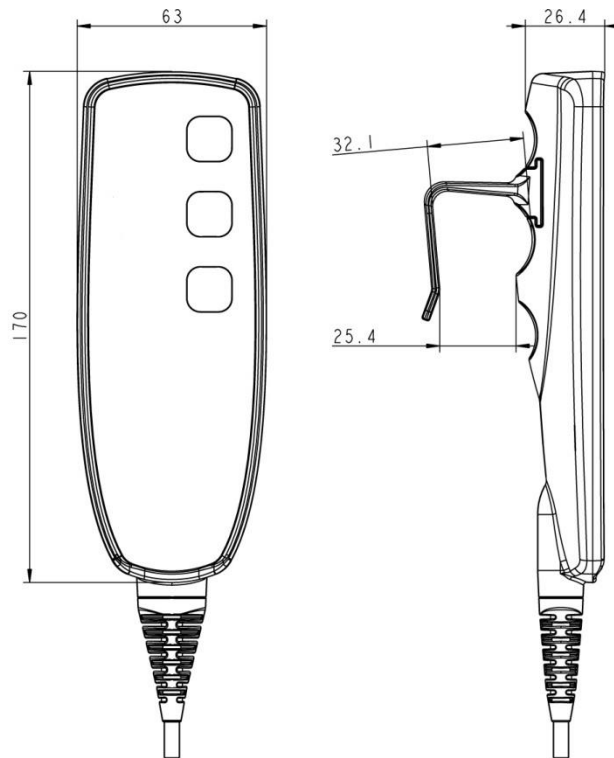

#### **WARNING**

No modification of this equipment is allowed.

### Control box for castors EBC

Model: *EBC002-00*

Voltage input: 24V AC

Weight: 225g

Protection class: IPX6

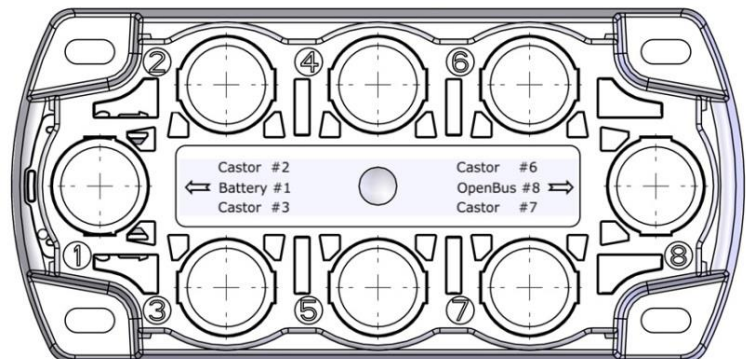

Motion sensor feedback – Auto-lock feature

Position feedback from each individual castor

Directional steering function

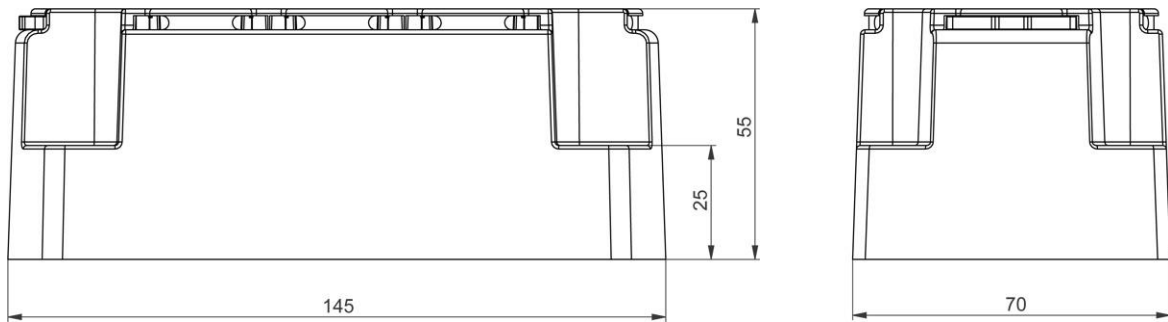

**WARNING**

No modification of this equipment is allowed.

### Modular junction box MJB

Model: *MJB0003000-1023*

Weight: 90g

Protection class: IPX6

Connections:

- Port 1      OpenBus
- Port2      Handset
- Port3      EBC

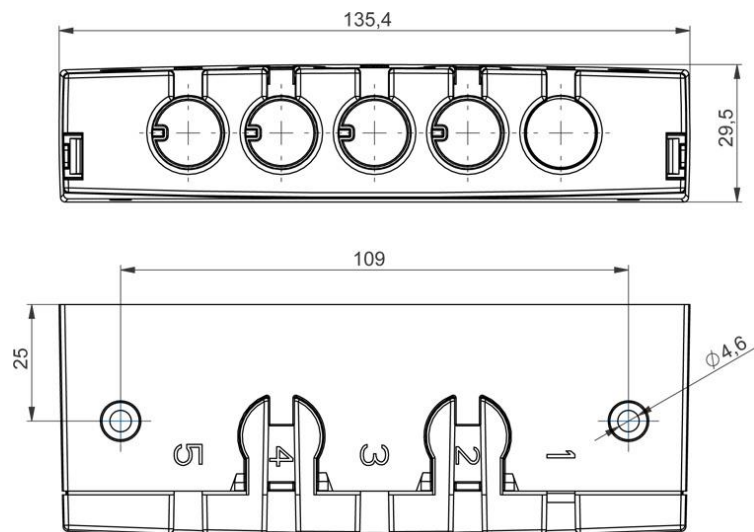

**WARNING**

No modification of this equipment is allowed.

## Castor extension cable

Models:    500mm  
              1000mm  
              1500mm  
              2000mm

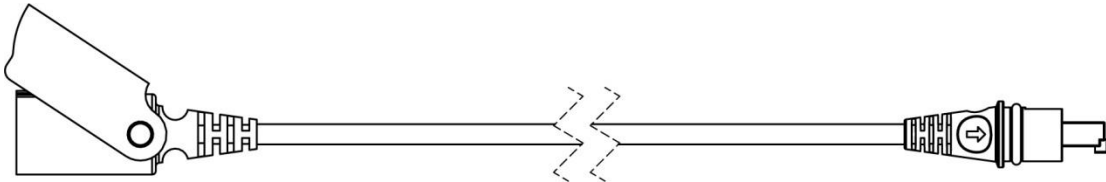

**WARNING**

No modification of this equipment is allowed.

## Cable between CB16/CB20 & EBC

Model: 0964810

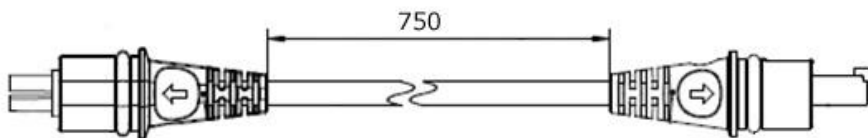

**WARNING**

No modification of this equipment is allowed.

## Modular plug cable

Model: 0964424-0300 (300mm)  
0964424-0500 (500mm)  
0964424-1250 (1250mm)  
0964568-1600 (1600mm)  
0964568-2500 (2500mm)

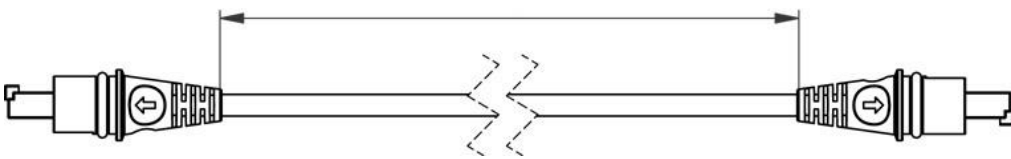

## Blind plug

Model: 0821008

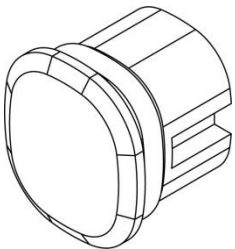

## CB6 blind plug

Model: 009271049-A

